



PROCESS CRITICAL COMPRESSORS

Naoki Akamo, Kobe Steel, Ltd, Japan, discusses BOG compressor applications.

Since producing the first high pressure reciprocating air compressor in 1915 (the first in Japan), Kobelco has delivered more than 2200 reciprocating compressors for various process gas applications, with an installed power total of approximately 1 400 000 kW. Kobelco reciprocating compressors have been furnished for applications in various industries, including oil refineries, petrochemical plants, LNG plants, and power plants.

As an example, hydrogen makeup compression required in the desulfurisation and/or the hydrocracking

processes in an oil refinery is one of the most difficult applications for any compressor due to the requirement to compress a very low molecular weight gas to very high pressures.

Kobelco manufactured the first large hydrogen makeup compressor (2700 kW) in the world for an Isomax plant in 1967. In addition, Kobelco has furnished reciprocating compressors for discharge pressures up to 700 barg. In nonlubricated services Kobelco has supplied bone dry hydrogen compressors for up to 220 barg discharge pressure.

For cryogenic service, the company developed and manufactured the first cryogenic gas reciprocating compressor in the world, for nitrogen service, operating with an inlet temperature near $-150\text{ }^{\circ}\text{C}$.

Utilising its existing technology base combined with and supported by a wealth of proven experience in many process gas services, the company developed and manufactured the LNG BOG reciprocating gas compressor. These reciprocating compressors are capable of handling inlet temperatures of $-150\text{ }^{\circ}\text{C}$, as required for LNG receiving terminals in Japan, and elsewhere. The company has now manufactured and supplied more than 60 low temperature, reciprocating compressors in various cryogenic services throughout the world.

LNG storage facilities and BOG compressors

LNG stored in the tank generates BOG during various operations and processes. This BOG should be recovered to minimise the energy loss and environmental impact, as well as provide additional revenue to the owner's operations.

Source of BOG are as follows:

- Heat ingress into the LNG storage tank, unloading systems and its associated piping.
- Boiling quality difference.

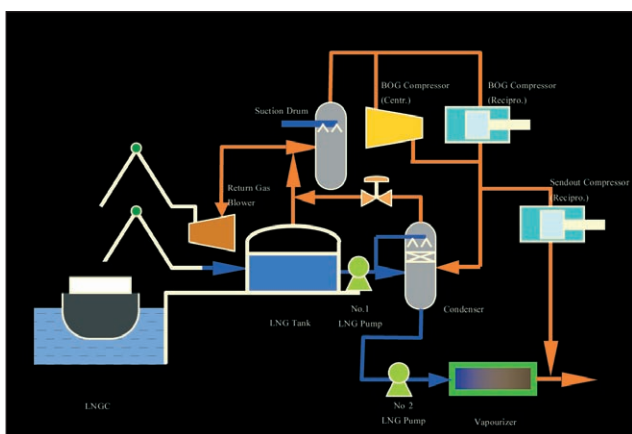

Figure 1. Typical LNG receiving terminal.

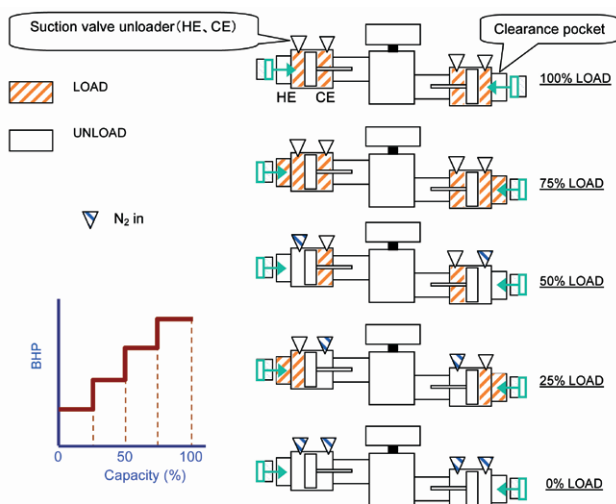

Figure 2. Reciprocating compressor capacity control system.

- Volume displacement during unloading.
- Heat input from unloading pumps.
- Barometric pressure variations.
- Pressure difference between the LNG carrier and the storage tank.

BOG recovery sequence is:

- BOG is pressurised to medium pressure.
- Pressurised BOG is reliquefied by LNG.
- Reliquefied LNG is pressurised and sent out to the vapouriser by the LNG pump.

The role of the BOG compressor is to compress the BOG to reliquefaction pressure levels. Figure 1 represents a 'typical LNG receiving terminal'. The flow, equipment layout, and BOG compressors are shown.

Key technology of reciprocating compressor for cryogenic service

Reciprocating compressor

Predictable performance

To accurately predict the performance, the company has its own database, accumulated from over 90 years of research and experience with process reciprocating compressors. Preheat is one of the most important considerations when designing BOG compressors in cryogenic service. Compressor capacity varies due to the actual inlet gas temperature inside the compressor cylinder and passageways. The inlet gas temperature is increased by heating from ambient, and, if the preheat is not considered, the compressor capacity will be lower than the required design capacity, and the discharge gas temperature will also be higher than expected. Furthermore, the effect of preheat varies, depending upon the compressor load and the inlet gas temperature. Therefore, preheat has a significant impact on the compressor design and performance, and must be considered. Kobelco accumulated a large database of field operating data, plus experimental data from the test bench under ultra low temperatures, and analysed the internal and external operating factors. Thus, the company has considered the effect of preheat, and is able to predict the most accurate compressor performance.

A wide operating range, combined with energy savings

For the LNG BOG process, centrifugal compressors and reciprocating compressors are normally both utilised in the plant design. The selection depends upon the BOG volume and the required discharge pressure. The compressor type is normally selected after a careful review of initial cost, as well as the operating costs of the LNG storage facilities, based upon a thorough understanding of the features of both types of compressors. The following is a comparison between a reciprocating compressor and a centrifugal compressor in cryogenic LNG BOG service.

Inlet gas temperature

The BOG compressor is located downstream of the LNG storage tank or suction drum with desuper heater and compresses the BOG, which has an inlet temperature of -100 to $-162\text{ }^{\circ}\text{C}$. Maintaining this inlet temperature range

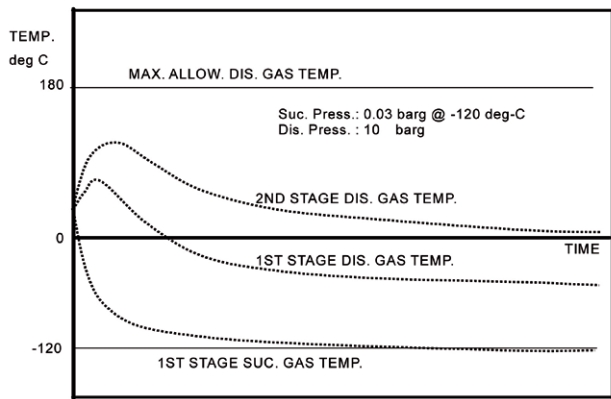

Figure 3. Temperature - time chart for two stage BOG compressor.

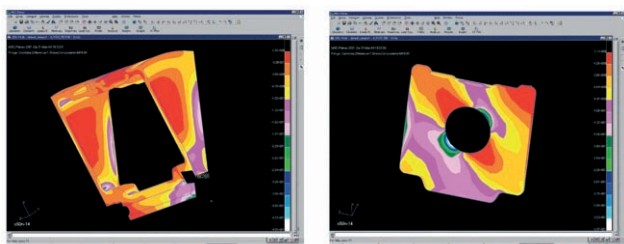

Figure 4. FEM analysis of piston.

Table 1. Comparison between reciprocating and centrifugal compressors

	Reciprocating	Centrifugal
Capacity	Small - middle	Middle - large
Dis.pressure	High	Low
Space ¹	Large	Small
Suction temperature range	Wide	Narrow
Capacity control	25, 50, 70, 100%	80 - 100%
Efficiency	High	Middle
Driver output ¹	Small	Large

is advantageous to the process and the process design efficiency, therefore, the suction inlet temperature should remain in this ultra low temperature range.

Centrifugal compressors are normally used when the boil off gas volume is quite large. However, the inlet gas temperature must be controlled within a certain level to maintain a consistent density, and to keep the centrifugal compressor from approaching surge, which would then recycle, thus further heating the gas.

Capacity control

LNG storage tank pressure is required to operate within certain plant design limits, even if the boil off gas volume greatly varies due to heat ingress during both the LNG receiving operation, and during the normal holding operation.

This requirement is met by the BOG compressor capacity control system. Since BOG storage tank volume is quite large compared to the BOG compressor capacity,

the storage tank pressure varies gradually, and the step type control will easily handle this rate of change, however, a large capacity control range is required. For Kobelco's reciprocating compressor, suction valve unloaders with clearance pockets allow for a wide range of capacity control. This step type capacity control is available in up to five steps. In this manner, a wide, smooth, capacity control range, i.e. (0 - 25% - 50% - 75% - 100%) is supplied by the reciprocating compressor (Figure 2).

On the other hand, for most centrifugal compressors, the control range is limited (by design) to approximately 80 - 100%, and the intake gas temperature and specific gravity should not vary since the centrifugal compressor must operate on its design curve, and only operate at least 10% above the surge or recycle point. In addition, should conditions of service vary, the reciprocating compressor can discharge to high pressures, regardless of the boil off gas volume, with no special requirement to control the inlet gas temperature, or avoid recycle operation as with the centrifugal compressor.

Therefore, the reciprocating compressor design is the most suitable compressor to be used for LNG BOG service in both LNG receiving terminals, as well as for LNG storage facilities.

Figure 2 shows the typical capacity control system for Kobelco's reciprocating compressor.

- Suction valve unloader. Used to completely unload a cylinder end where 50% or 100% step of unloading is required.
- Clearance pocket unloader. Clearance pockets are the fixed volume type and mounted in the cylinder head.

Since the reciprocating compressor controls can correspond sufficiently to changes in the boil off gas volume, and thus reduce the overall operating costs, they are always adopted for LNG BOG service at LNG receiving/storage facilities.

The centrifugal compressor is usually only required when the boil off gas volume becomes quite large during actual LNG receiving operations. These events are quite limited in duration, and may only occur once or twice per month, when the tanker is connected to the unloading arms. Occasionally, when several LNG storage tanks are filled and established, an additional boil off gas demand may be called for during the course of normal holding operations, as well as during LNG receiving. For this type of dual operation, a centrifugal compressor for base load conditions handles large volumes, and the reciprocating compressor handles the fluctuating portion of the LNG boil off gas volume.

Table 1 shows the general comparison between reciprocating and centrifugal compressors.

Advantage of horizontal piston ring type compressor

For the cryogenic services, either the horizontal ring type or vertical labyrinth type compressors are used, but it is very important to understand the basic difference between these two designs.

Table 2 shows the comparison between the horizontal ring type and the vertical labyrinth type compressors.

Efficiency

The efficiency of piston ring type compressors is much higher than for the labyrinth type. For the vertical labyrinth type, leakage of low temperature gas around the piston, piston rods and labyrinths is much higher, with a resultant energy loss. Hence, the piston ring type compressor is more suitable in LNG BOG because the critical parts such as piston, rider and piston rod packing rings are self lubricated parts with better sealing characteristics, as well as excellent wear resistance in cryogenic service.

Maintenance

In the case of the vertical labyrinth type, centering between the piston and the cylinder is a critical tolerance and must be carefully considered during assembly. This is a difficult operation to perform at site due to the small tolerance requirements. Furthermore, an elevated overhead crane is required to access the cylinders.

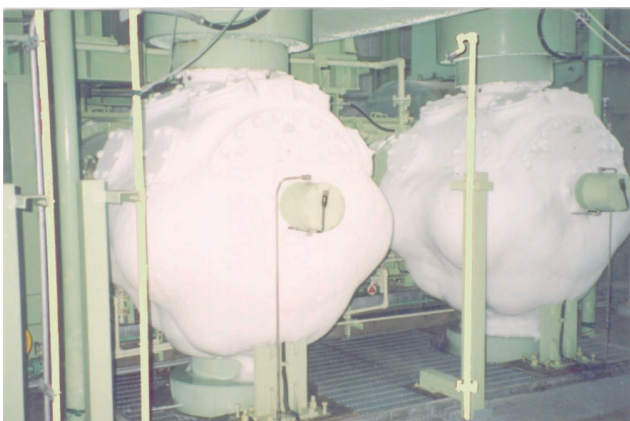

Figure 5. LNG BOG compressor.



Figure 6. LNG BOG compressor.

Hence, maintenance requires more time and a skilled specialist is always needed. For the piston ring type, maintenance work is much easier and faster because no special adjustment of the piston is necessary.

Cooling water system

A typical BOG compressor is a two stage compressor, designed to compress the gas from atmospheric pressure up to approximately 10 barg. A cooling water jacket and piping are not necessary with a piston ring type compressor under these conditions.

Since vertical labyrinth type compressors require a water cooled system for the crankcase, as well as the second stage, this means an additional operating cost, as well as potential maintenance. In addition, extra plot space and energy are also necessary.

Unbalance

Kobelco's (piston ring type) reciprocating compressor is designed with a horizontally balanced/opposed type frame, and in this design the cylinders are arranged opposite each other as a means of balancing the reciprocating inertial forces. As a result, the forces are balanced, and the unbalanced couple becomes relatively small, significantly reducing the vibration, and allowing for an easy foundation design.

Also, because the piping is routed at a lower level, rigid supports can be used, and vibration is lower than for a vertical design.

Lower maintenance

Continuous long term and trouble free operation is a critical consideration since it will always be directly related to the owner's bottom line.

Long ring life

Rings such as the piston, rider and piston rod packing rings are critical wear parts in any compressor application, and should be evaluated during any performance evaluation involving reciprocating compressors.

Suitable materials are normally formulated into the self lubricated material according to the process gas composition, gas temperature, humidity and calculated bearing pressures. However, in cryogenic services, the material characteristics may be different from those in normal ambient temperature service. Therefore, it is extremely important to properly select the base and mating materials of these critical wear parts.

Following is the typical experience of the Kobelco LNG BOG reciprocating compressors under commercial operation.

Predicted ring life

From the database, the life of conventional rings was approximately 8000 hours. So far, the wearing rate of the new ring design has been drastically reduced, and predicted life of rings such as piston, rider, and piston rod packing rings has reached more than 24 000 hours.

The company evaluates each application based upon the expected operating conditions,

Table 2. Comparison between horizontal ring and vertical labyrinth

	Horizontal piston ring type		Vertical labyrinth type	
Efficiency	High	O	Low	Δ
Maintenance	Easy	O	Difficult	X
Cooling water system	Not required	O	Required	X
Unbalance	Small	O	Big	X
Centre of gravity	Low	O	High	X
Space	Wide	Δ	Tall	Δ

as well as the selected ring type and shape, including any external factors which must be taken into account.

Suction and discharge valves

The most suitable type of valve is employed for the operating condition. Valve seats and guards are made of austenitic stainless steel, and the gas tight face contacting with the valve plate is super finished. Valve plates and valve springs are made of special alloy steel having excellent low temperature tenacity and fatigue strength, and are given a special finish treatment after machining.

Large diameter cylinders and pistons

Large cylinders are preferable to save installation space and maintenance cost due to the fewest number of cylinders, but various effects should be considered.

As mentioned before, a typical LNG BOG compressor is a two stage compressor designed to compress the gas from atmospheric pressure to 10 barg. Compressor cylinders are nonlubricated, and without cooling jackets due to the low gas temperature during normal operation.

When the compressor starts up at the prevailing ambient temperature under a loaded condition, the second stage discharge temperature will increase approximately 110 °C, and then drop (Figure 3). As a result, those parts in contact with the gas, such as the cylinder, piston, etc. are exposed to a very wide temperature change and special consideration should be taken to evaluate those parts for any abnormal deformation and partial stress. Of particular concern is the piston. The piston should be light in weight, with high stiffness to handle the wide temperature change.

Table 3. Compressor specification

Type	Horizontal balanced opposed
Model	KR50-4
No. of stage	2
No. of cylinder	4
Suction temperature	-155 to -100 °C
Inlet pressure	0.03 barg
Discharge pressure	10 barg
Capacity	15 000 kg/h
Motor power	1600 kW

Kobelco applies finite element methods (FEM) to analyse piston deformation and stress levels under the various loading conditions, including assembly, and gas load, as well as the wide temperature change and inertia forces (Figure 4).

With these factors in mind, Kobelco has manufactured more than 50 large (max. 1070 mm) cylinders in the past 20 years and the results have been extremely successful.

Conclusion

The demand for large LNG storage facilities is growing all over the world. LNG boil off gas compressors are critical process compressors. These compressors are an essential and vital part of any LNG plant, and the failure of the BOG compressors will cause a serious loss of profit to the owners and operators of these plants. In this business, failure is never an option. **LNG**